

DIN 906

Screw plug

with internal hexagon and conical thread

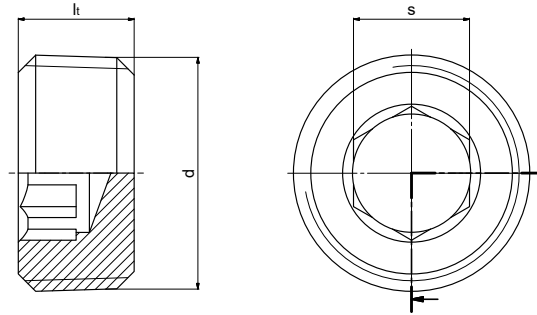

Application areas:

- Mechanical engineering, gear manufacturing, automotive and many others
- For counter bores as per DIN ISO 261 and DIN EN ISO 228-1

Material:

- Steel 11SMnPb30+C (1.0718)
DIN EN 10277-3 ultrasonic and crack tested or "HD-quality"
- Stainless steel 1.4305 / 1.4571
- Other materials upon request

Coating:

- Cr-(VI) free: nano passivated A3K/Zn Nano (ISO 4042)
- ZNNI as per VDA 235.104-25
- Other coatings upon request

d		lt	s	Weight
Metric conical thread	(Withworth-) pipe thread	js16	D12	-kg per 100 pieces
DIN 158-1 (short version)	DIN 3858 Tolerance class 2 (short version)			
M6 x 1 conical*	—	6	3	0,08
M8 x 1 conical	—	8	4	0,21
M10 x 1 conical	—	8	5	0,34
M12 x 1,5 conical	—	10	6	0,61
—	R 1/4	10	7	0,70
M14 x 1,5 conical	—	10	7	0,81
M16 x 1,5 conical	—	10	8	1,10
—	R 3/8	10	8	1,22
M18 x 1,5 conical	—	10	8	1,46
M20 x 1,5 conical	—	10	10	1,76
—	R 1/2	10	10	1,90
M22 x 1,5 conical	—	10	10	2,20
—	R 5/8*	12	12	2,90
M24 x 1,5 conical	—	12	12	3,08
M26 x 1,5 conical	—	12	12	3,86
—	M27 x 2 conical	12	12	4,02
M30 x 1,5 conical	M30 x 2 conical	12	17	4,40
—	M33 x 2 conical	12	17	5,75
M35 x 1,5 conical*	—	15	19	8,30
M36 x 1,5 conical	M36 x 2 conical	15	19	8,52
M38 x 1,5 conical	—	15	19	9,44
—	M39 x 2 conical	15	19	10,30
M42 x 1,5 conical	M42 x 2 conical	18	22	13,50
M45 x 1,5 conical	M45 x 2 conical	18	22	16,70
M48 x 1,5 conical	M48 x 2 conical	20	24	21,40
M52 x 1,5 conical	M52 x 2 conical	20	24	25,30
—	M56 x 2 conical	22	32	27,40
—	M60 x 2 conical	22	32	35,00

* This thread size is not included in DIN 906, measurements only refer to DIN 906.

** Cylindrical version upon request!