

HN8-UN-OR

Sealing plug

with UNF, UN thread as per ISO 11926 (SAEJ514)

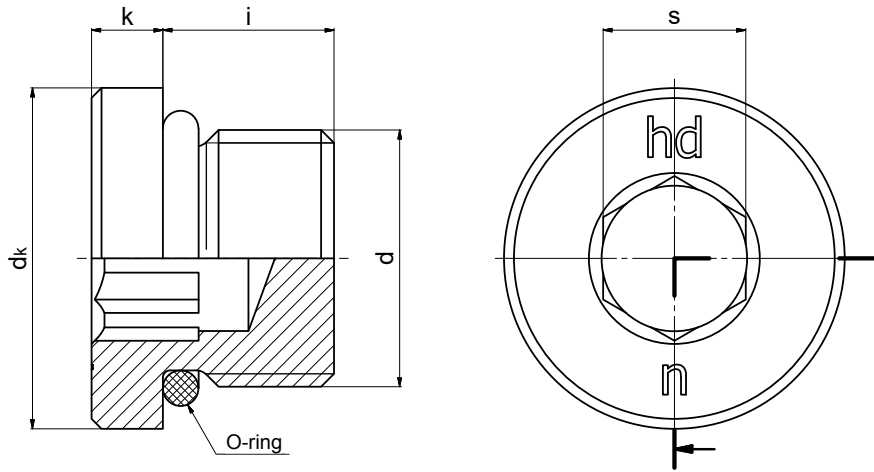

Application areas:

- Hydraulics
- For counterbores as per ISO 11926-1
- Can be loosened and tightened repeatedly

O-ring acc. DIN 3601:

- NBR 90 Shore -30°C to +100°C (-22 F to +212 F)
- FKM 90 Shore -20°C to +200°C (-4 F to +392 F)
- Other temperature ranges upon request

Material:

- Steel 11SMnPb30+C (1.0718)
DIN EN 10277-3 ultrasonic and crack tested, or "HD-quality"
- Stainless steel 1.4305 / 1.4571
- Other materials upon request

Coating:

- Cr-(VI) free: nano passivated A3K/Zn Nano (ISO 4042)
- ZNNI as per VDA 235.104-25
- Other coatings upon request

d		k	dk	i	s	Tightening torque Nm*	Operating pressure MPa *** (1 MPa = 10 bar)	Weight ~kg per 100 pieces
Thread as per ISO 11926-4								
Tol.-class 2A as per ANSI B1.1		-0,25	±0,15	±0,2	+0,13			
5/16-24 UNF	—	2,75	11,1	7,5	3,18	7	41,4	0,35
3/8-24 UNF	—	2,75	12,7	7,5	3,96	14	41,4	0,61
7/16-20 UNF	—	2,9	14,3	9,1	4,76	20	41,4	0,73
1/2-20 UNF	—	2,9	15,85	9,1	5,56	27	41,4	0,96
9/16-18 UNF	—	2,9	17,45	10	6,35	45	63	1,25
3/4-16 UNF	—	3,75	22,2	11,1	7,94	85	63	2,71
7/8-14 UNF	—	3,95	25,4	12,7	9,52	110	63	4,05
—	1 1/16-12 UN	4,6	31,75	15,1	14,3	170	41,4	6,64
—	1 3/16-12 UN	4,6	34,9	15,1	14,3	235	41,4	9,40
—	1 5/16-12 UN	4,6	38,1	15,1	15,88	270	41,4	10,59
—	1 5/8-12 UN	4,6	47,6	15,1	19,05	340	25	16,95
—	1 7/8-12 UN	4,6	53,95	15,1	19,05	420	25	23,67
—	2 1/2-12 UN	4,6	69,85	15,1	19,05	510	20,7	41,55

* Recommendation for counter threads made of untempered steel. Its reaction depends on the material, coating and quality and must be verified by the customer in each specific application case!

** Screw plugs made of stainless steel can be stamped additionally with a material mark on the front face.

*** Recommendation for a maximum operating pressure under industry-standard conditions.

As the behaviour depends on certain facts such as pressure increase rate, number of cycles, temperature, viscosity and mating thread strength, it must be verified by the customer if operating circumstances are exceptionally tough. We are able to support our customers, if needed.