

DIN 908 MAG

Screw plug w/ magnet

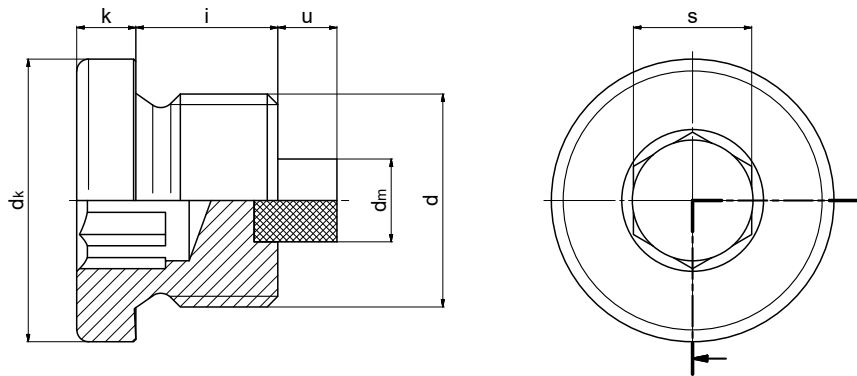

Function:

- Ferromagnetic wear debris is extracted from inside the aggregate with the help of the magnet.

Application areas:

- Engines, gearboxes, hydraulic equipment, powertrain and many others
- for counter bores as per DIN 3852-1 and ISO 3852-2
- usually for use with sealing rings in acc. with DIN 7603

Industries:

- Mechanical engineering, gear manufacturing, steel construction, chemicals, automotive and many others

Material (screw plug):

- Steel 11SMnPb30+C (1.0718) DIN EN 10227-3 ultrasonic and crack tested or "HD-quality"
- Stainless steel 1.4305 / 1.4571
- other materials upon request

Material (magnet):

- AlNiCo
- other magnets upon request

Coating (screw plug):

- Cr-(VI) free: nano passivated A3K/Zn Nano (ISO 4042)
- ZNNI as per VDA 235.104-25
- other coatings upon request

d		k	dk***	i	s	u	dm	Weight
Metric fine thread	Pipe thread							
DIN 13	DIN EN ISO 228	+0,5	h14	±0,2	D12	max.	±0,2	~kg per 100 pieces
M8 x 1**	—	3	12	8	4	3,5*	4	0,45
M10 x 1	—	3	14	8	5	3,5*	5	0,65
M12 x 1,5	—	3	17	12	6	3,5*	5	1,15
—	—	3	18	12	6	3,5*	5	1,50
M14 x 1,5	—	3	19	12	6	3,5*	5	1,65
M16 x 1,5	—	3	21	12	8	3,5*	7	1,95
—	—	3	22	12	8	3,5*	7	2,15
M18 x 1,5	—	4	23	12	8	3,5*	7	2,85
M20 x 1,5	—	4	25	14	10	3,5*	7	3,75
—	—	4	26	14	10	3,5*	7	4,10
M22 x 1,5	—	4	27	14	10	3,5*	7	4,80
M24 x 1,5	—	4	29	14	12	3,5*	7	5,40
M26 x 1,5	—	4	31	16	12	3,5*	7	6,90
—	M27 x 2	4	32	16	12	3,5*	7	7,40
M30 x 1,5	M30 x 2	4	36	16	17	3,5*	10	8,45
—	M33 x 2	5	39	16	17	3,5*	10	11,15
M36 x 1,5	M36 x 2	5	42	16	19	3,5*	10	13,45
M38 x 1,5	—	5	44	16	19	3,5*	10	14,95
—	M39 x 2	5	46	16	19	3,5*	10	16,40
M42 x 1,5	M42 x 2	5	49	16	22	3,5*	10	18,75
M45 x 1,5	M45 x 2	5	52	16	22	3,5*	10	21,50
M48 x 1,5	M48 x 2	5	55	16	24	3,5*	10	24,60
M52 x 1,5	M52 x 2	5	60	16	24	3,5*	10	30,20
—	—	5	62	20	32	3,5*	10	32,00
—	M56 x 2	5	64	20	32	3,5*	10	38,60
—	M60 x 2	5	68	20	32	3,5*	10	44,50
—	M64 x 2	5	72	20	32	3,5*	10	53,00

* Other magnet excess lengths upon request.

** This thread size is not contained in DIN 908! Measurements based on DIN 908.

*** Values that exceed the outer diameter „dk“ due to feed scoring and/or surface coating by up to 0.1 mm are acceptable.