

HNP

Pneumatic screw plug

as per DIN ISO 16030,
with o-ring

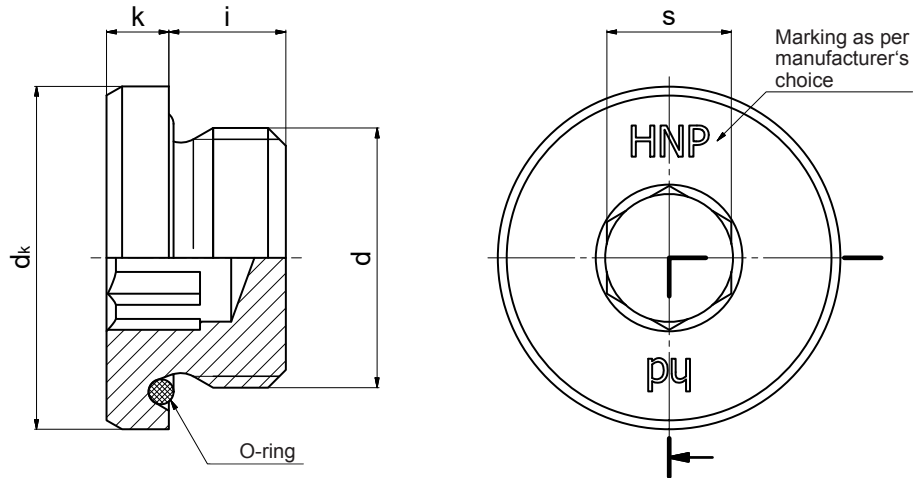

Application areas:

- Pneumatic components
- Designed for an operating pressure between -0,09 MPa (-0,9 bar) and 1,6 MPa (16 bar)
- For counterbores as DIN ISO 16030
- Can be tightend and loosend repeatedly

O-ring acc. DIN 3601:

- NBR 70 Shore -20°C to +120°C (-4 F to +248 F)
- FKM 80 Shore -20°C to +200°C (-4 F to +392 F)
- Other temperature ranges upon request

Material:

- Steel 11SMnPb30+C (1.0718)
DIN EN 10227-3 ultrasonic and crack tested, or "HD-quality"
- Stainless steel 1.4305 / 1.4571
- Other materials upon request

Coating:

- Cr-(VI) free: nano passivated A3K/Zn Nano (ISO 4042)
- ZNNI as per VDA 235.104-25
- Other coatings upon request

d		k	dk	i	s	Tightening torque	Weight
Metric regular thread	Pipe thread						
DIN 13	DIN EN ISO 228	±0,3	h14	±0,3	D12	Nm***	-kg per 100 pieces
M 3	—	3,5	6	3,5*	2	0,3	0,08
M 5	—	2	8	4	2,5	0,8	0,09
M 7	—	2,5	11	5,5	3	2	0,25
—	G 1/8 A	3	14	5,5	5	3	0,44
—	G 1/4 A	3,5	18	6,5	6	6	0,98
—	G 3/8 A	4	22	7,5	8	10	1,80
—	G 1/2 A	4,5	26	9	10	15	2,95
—	G 3/4 A	4,5	32	10,5	12	22	5,40
—	G 7/8 A**	5	36	11,5	17	30	7,20
—	G 1 A	5	39	11,5	17	35	8,50

* Outside of standard DIN ISO 16030.

** Deliverable, despite no standard dimension!

*** Recommendation for counter threads made of untempered steel. The reaction depends on their material, coating and quality and must be verified by the customer in case of each specific application.